

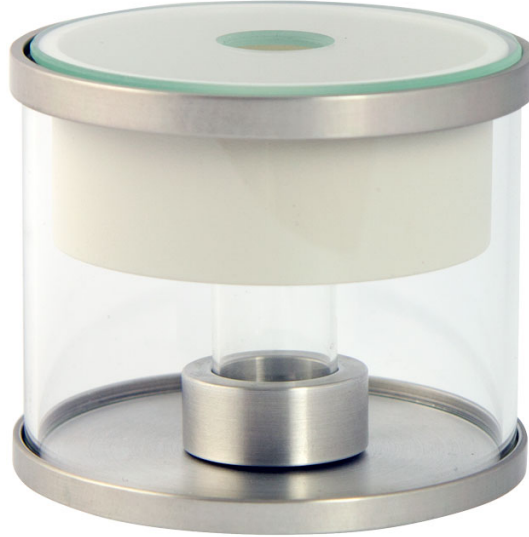

More information on the
website

radwag.com/tr/info,w1,284

Pipet kalibrasyonu için XA17 - 17ml Adaptör



The drawings, photos and graphics used are for illustrative purposes only.

Genel Açıklama

XA17 pipette calibration adapter enables calibration and/or verification of piston pipettes by means of a gravimetric method using the XA analytical balance.

Set content:

- base
- weighing pan
- weighing vessel
- evaporation ring
- glass chamber with an opening for dosing

Evaporation ring is an integral part of the adapter that increases relative humidity inside the weighing chamber. With this evaporation of the liquid during calibration/verification is stopped.

An integrated weighing pan enables centric loading of the vessel in the weighing chamber. The weighing pan and the vessel are housed in a glass chamber featuring an opening allowing the user to dispense liquid through it, and reducing air drafts.

Vessel capacity: 17 ml

Adapters for pipettes calibration

Pipette calibration adapters are intended for calibration and verification of piston pipettes using gravimetric method. Use of the pipette calibration adapter reduces maximum capacity of the balance by the mass of the weighing vessel. The table presents the minimum requirements in accordance with ISO 8655 standard. It also enables to select suitable adapter for pipette calibration and respective balance version.

Selected volume ¹ of apparatus under test V	Resolution mg	Repeatability and linearity mg	Recommended balance					
$1 \mu\text{l} \leq V \leq 10 \mu\text{l}$	0.001	0.002	MYA 21.5Y	XA 6/21.5Y.M.A XA 6/21.5Y.M	XA 82/220.5Y.A XA 82/220.5Y	XA 120/250.5Y.A XA 120/250.5Y		
$10 \mu\text{l} < V \leq 100 \mu\text{l}$	0.01	0.02						
$100 \mu\text{l} < V \leq 1000 \mu\text{l}$	0.1	0.2						
$1 \text{ ml} < V \leq 10 \text{ ml}$	0.1	0.2						
Adapter for pipette calibration			MY 11	XA 11	XA 17	XA 100	XA 17	XA 100
Maximum vessel capacity			11 ml	11 ml	17 ml	100 ml	17 ml	100 ml
Weighing vessel mass			~10 g	~10 g	~11 g	~65 g	~11 g	~65 g

¹ For practical purposes, the nominal volume may be used to choose the balance. [Reference: ISO8655-6:2002, pg. 2]

If the standard uncertainty of measurement of the balance is known (e.g. from the balance calibration certificate), it may be used instead of the repeatability and linearity. The standard uncertainty of measurement shall not be more than two to three times the resolution. [Reference: ISO8655-6:2002, pg. 2]

İle uyumlu

XA 5Y Analitik Terazî

XA 5Y.A Analitik Terazî

Cihaz boyutları

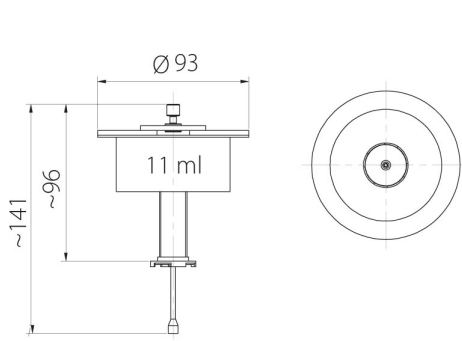

MY11



XA11



XA17



XA100