



PS 8100.R2.M Precision Balance

More information on the website
radwag.com/en/info,w1,3YL



PS 8100.R2.M Precision Balance

The drawings, photos and graphics used are for illustrative purposes only.

Functions



Autotest



Dosing



Percent Weighing



Totalizing



Parts counting



Peak hold



Newton unit
measurement



Statistics



Checkweighing



GLP Procedures



Animal weighing



Density determination

Datasheet

PS 8100.R2.M Precision Balance	
Metrological parameters	
Maximum capacity [Max]	8100 g
Minimum load	500 mg
Readability [d]	10 mg
Verification unit [e]	100 mg
Tare range	-8100 g
Standard repeatability [5% Max]	5 mg
Standard repeatability [Max]	10 mg
Standard minimum weight (USP)	10 g
Standard minimum weight (U=1%, k=2)	1 g
Linearity	±20 mg
Stabilization time	1,5 s
Adjustment	internal (automatic)
OIML Class	II
Physical parameters	
Leveling system	manual
Display	LCD (backlit)
Delivery components	Balance, weighing pan, weighing pan shield, power supply
Weighing pan dimensions	195×195 mm
Device dimensions	333x206x107 mm
Packaging dimensions	475×380×345 mm
Net weight	4,5 kg
Gross weight	7,5 kg
Construction	
Protection class	IP 43
Communication interface	
Communication interface	2×RS232 ¹ , USB-A, USB-B, Wi-Fi (option)
Electrical parameters	
Power supply	Adapter: 100 – 240V AC 50/60Hz 0,6A; 12V DC 1,2A Balance: 12 – 15V DC 0,4A max
Power consumption	4 W
Environmental conditions	
Operating temperature	+10 ÷ +40 °C
Storage temperature	-20 ÷ +50 °C

Repeatability is expressed as a standard deviation from 10 weighing cycles. Stabilization time depends on the ambient conditions and the dynamics of weighing pan loading; specified for FAST profile. 1 Barcode scanners, available as weighing instrument accessory, communicate with the instrument via RS232 interface exclusively.

* Wi-Fi® is a registered trademark of Wi-Fi® Alliance.



Extra payment for verification



Accessories

Balance Storage Case
Antivibration Tables

Displays
Density determination KIT

Power Adapters
Cigarette lighter receptacle power supply cables
USB cable (scale - printer)
Barcode scanners
RS 232, RS 485 cables

Protective cover for balances
Receipt Printer
RS 232, RS 485 cables
Under-pan weighing
RS 232 cables (scale - printer)

Software

RAD-KEY
Alibi Reader
RADWAG Development Studio

R Panel
R-LAB

Device dimensions

PS 8100.R2.M Precision Balance

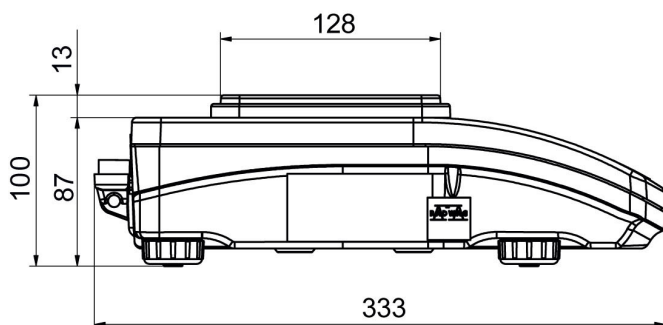

PS R, d = 1mg

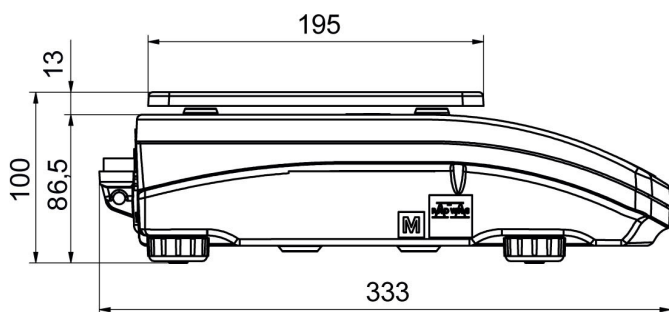
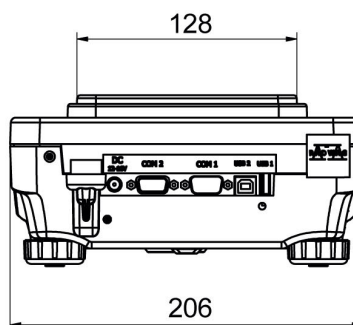

PS R, d = 10 mg

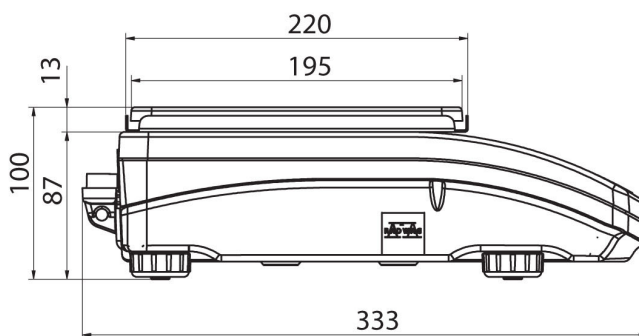
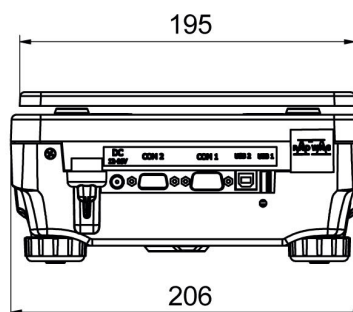

PS R.M, d = 10 mg

