



More information on the website
radwag.com/en/info,w1,MJT

PS 360.R1 Precision Balance



PS 360.R1 Precision Balance

The drawings, photos and graphics used are for illustrative purposes only.

Functions



Autotest



Dosing



Percent Weighing



Totalizing



Parts counting



Peak hold



Newton unit
measurement



Statistics



Checkweighing



GLP Procedures



Animal weighing



Density determination

Datasheet

	PS 360.R1 Precision Balance
Metrological parameters	
Maximum capacity [Max]	360 g
Minimum load	20 mg
Readability [d]	0,001 g
Tare range	-360 g
Repeatability (Max)	0,001 g
Repeatability (5% Max)	0,0005 g
Linearity	±0,002 g
Stabilization time	2 s
Adjustment	external
Physical parameters	
Leveling system	manual
Display	LCD (backlit)
Delivery components	Balance, weighing pan, weighing pan shield, grounding bumper ×1, bumper ×3, power supply.
Weighing pan dimensions	128×128 mm
Packaging dimensions	475×380×345 mm
Net weight	3,2 kg
Gross weight	5 kg
Construction	
Protection class	IP 43
Communication interface	
Communication interface	2×RS232, USB-A, USB-B, Wi-Fi (option)
Electrical parameters	
Power supply	Adapter: 100 – 240V AC 50/60Hz 0,6A; 12V DC 1,2A Balance: 12 – 15V DC 0,4A max
Power consumption	4 W
Environmental conditions	
Operating temperature	+10 ÷ +40 °C

* Wi-Fi® is a registered trademark of Wi-Fi® Alliance.



Accessories

Balance Storage Case	RS 232, RS 485 cables
Antivibration Tables	Displays
Power Adapters	Draft Shield
Cigarette lighter receptacle power supply cables	Receipt Printer
USB cable (scale - printer)	Protective cover for balances
Density determination KIT	RS 232, RS 485 cables
Barcode scanners	Under-pan weighing
Anti-Draft Chamber for Balances with a 128×128 mm Weighing Pan	RS 232 cables (scale - printer)

Software

RAD-KEY

R Panel

Device dimensions

PS 360.R1 Precision Balance

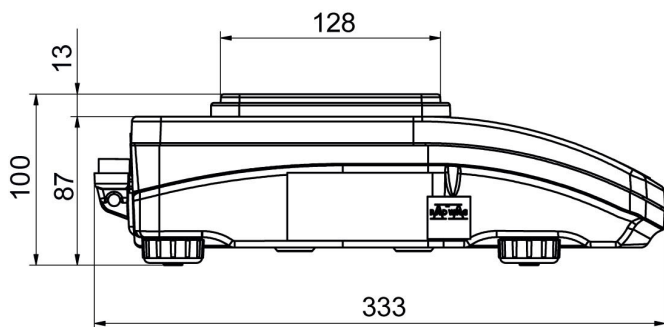

PS R, d = 1mg

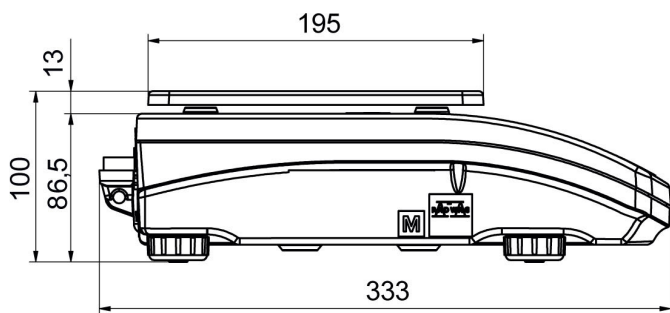
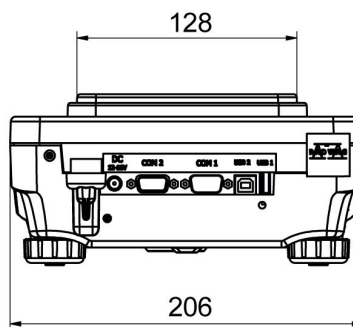

PS R, d = 10 mg

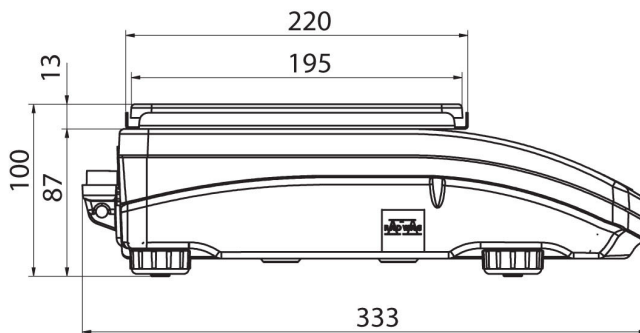
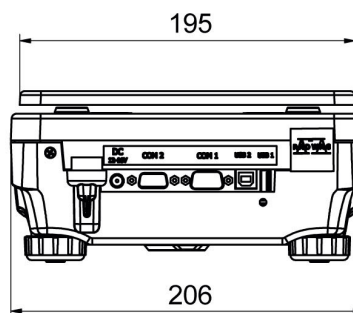

PS R.M, d = 10 mg

