

# LA66-200C Weigh Module

For Bellows Type Load Cells

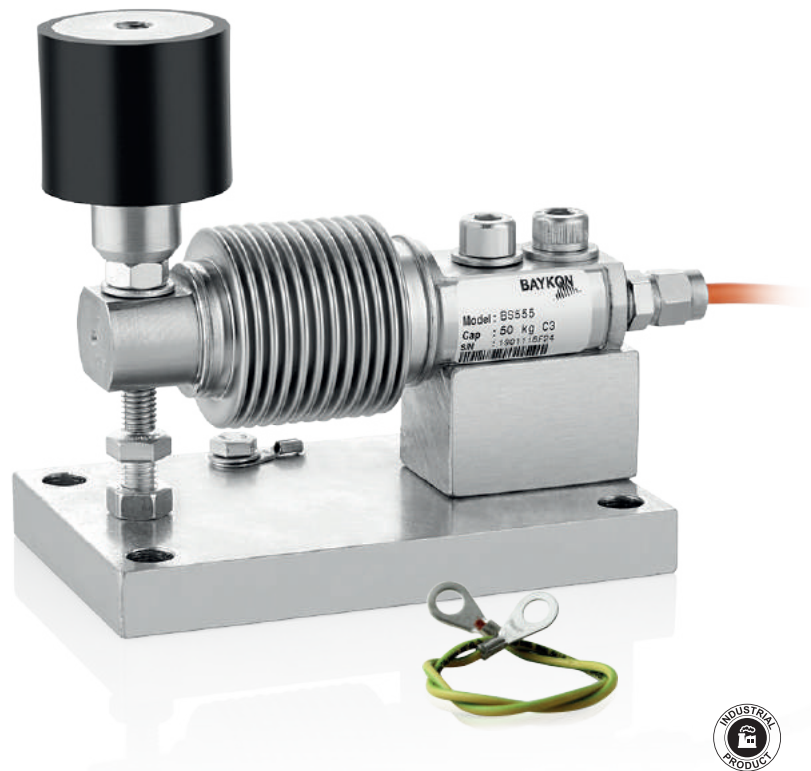

## Applications



Floor Scales

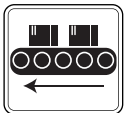

Conveyor Scales



Industrial Processes

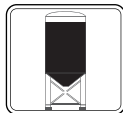

Tank, Silo Bunker

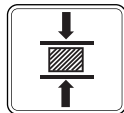

Testing Machines

## Key Features

- Capacity: Between 10 kg and 500 kg
- Easy to install and maintain
- Rubber adaptor absorbs shocks and vibrations
- Integrated overload protection
- Standard galvanized steel
- Stainless steel option

LA66-200C weigh module is cost effective solution for low capacity weighing systems. Thanks to its support consisting of rubber with steel plates. Provides durable load introduction and shock absorption for bellows load cells. Provides safe operation with integrated overload protection.

# Technical Specifications

## Dimensions (mm)

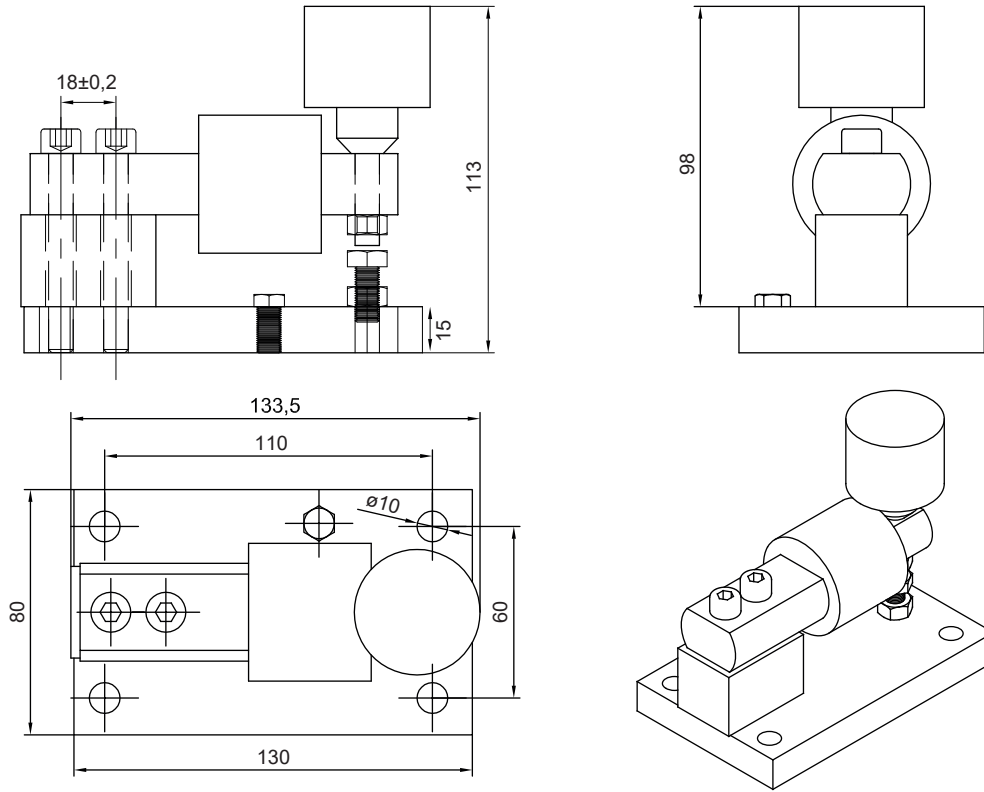

## Application

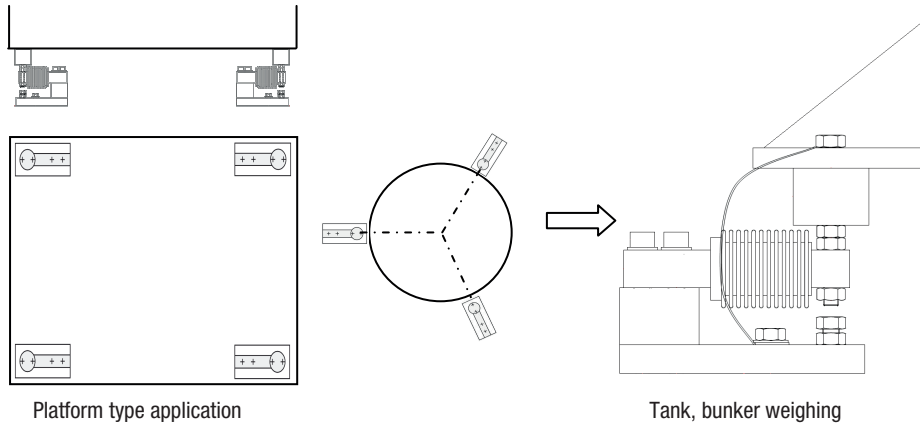

## Load cells compatible with the kit

Compatible Load Cell Types	
Brand	Model
Baykon	BS555
Flintec	SB8
Vishay	355