

# LEB / FL- RC - SP Weigh Module

For Beam Load Cells

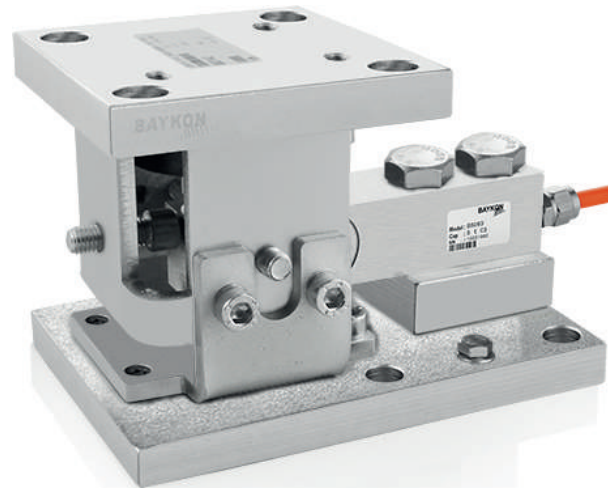

## Applications



Tank & Silo



Floor Scales

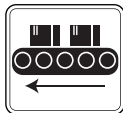

Conveyor Scales

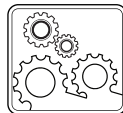

Industrial Processes

## Key Features

- Variants available for various operational and environmental conditions
- Installations without load cells.
- Easy load cell replacement
- Capacities from 100 kg to 5000 kg
- Integrated lift-up protection
- Painted, galvanized or 304/316 SS models
- PVC coated for acidic environments

Baykon LEB/FL-RC-SP weigh modules are designed for tank, silo, hopper and platform scales. Variants available to provide best weighing performance for different operational and environmental conditions such as highest accuracy demand, scales with very high speed mixer, over heated reactors and shock loading.

LEB/FL-RC-SP modules can be installed without load cell to protect load cell during montage and welding works. It offers very easy load cell replacement. Integrated lift-up protection is standard. Power coated, galvanized and stainless steel models are available. PVC coated models can be supplied for acidic corrosive environments

**BAYKON**  
Industrial Weighing Systems

## Variants For Different Operational And Environmental Conditions

LEB/FL-RC-SP have different designs for all type of environmental disturbances which affects weighing performance and accuracy such as dynamic forces created by mixers and motors, thermal expansion because of over heating, environmental vibrations, etc.

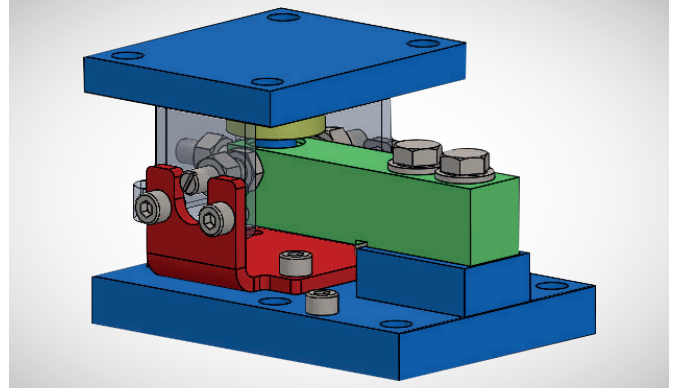
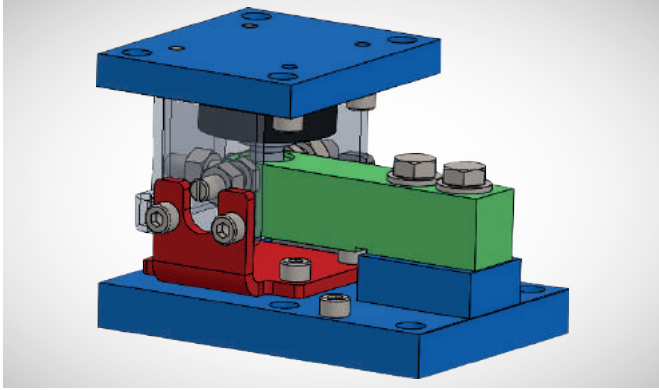

### LEB/FL

Rubber element with flanch

#### Applications:

Provides perfect performance against high lateral dynamic forces created high speed mixers, conveyor motors and shock loading.



### LEB/RC

Rocker pin

#### Applications:

Provides highest accuracy for tank, reactor and platform scales. It can be used with low speed mixer and motors with moderate lateral forces and low heated reactors.



### LEB/SP

Sliding pin

#### Applications:

Provides best performance for over heated reactors and platforms in the area having big temperature changes. It can be used with low speed mixer and motors with moderate lateral forces.

	LEB/FL	LEB/RC	LEB/SP
Weighing accuracy	High	Very High	High
Shock loading	High	Normal	Normal
Mixer speed	High	Medium	Medium
Thermal expansion	Medium	Medium	Extreme
Lift-up protection	Standard	Standard	Standard
Bumpers up to 3D	Standard	Standard	Standard

## Installation Without Load Cell Easy Load Cell Replacement

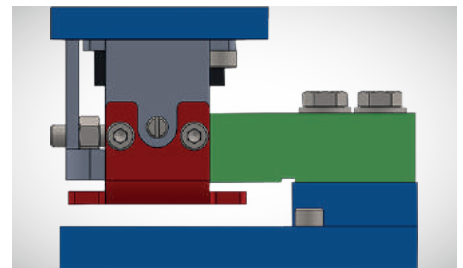
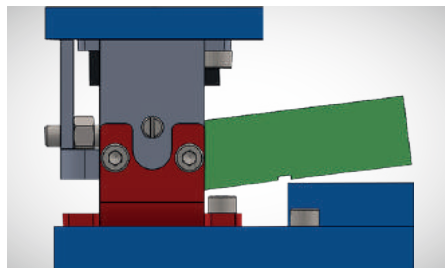
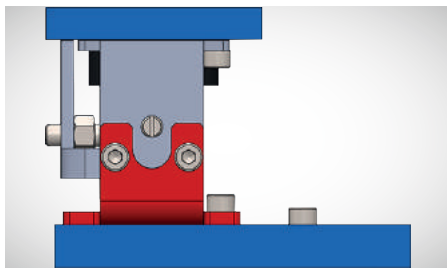

Thanks to support plates enable installation without load cell. Load cell can be replaced easily without disassembling the module. Support plates are removed up to operate as lift-up parts.

## Integrated Lift-Up Protection

LEB/FL-RC-SP weigh modules have integrated lift-up protection for safety.

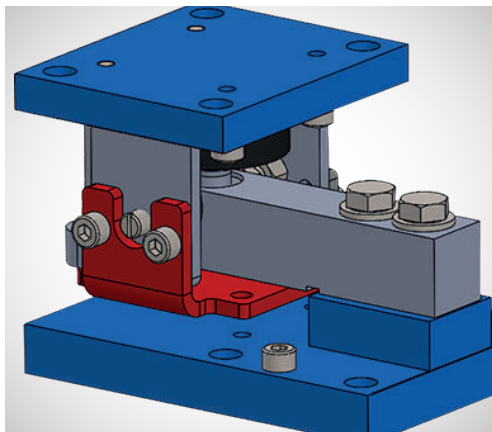

## Integrated Bumpers up to 3 Directions

Integrated up to 3 bumpers to block lateral movement

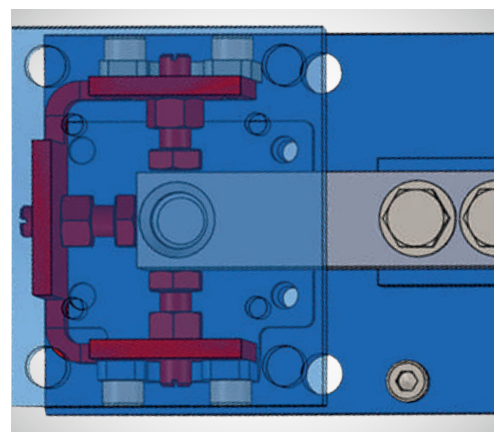

## PVC Coated Module For Corrosive Acidic Areas

Optional PVC coated weigh modules are available for acidic corrosive environments where even stainless materials cannot be used.



# Technical Specifications

## Dimensions (mm)

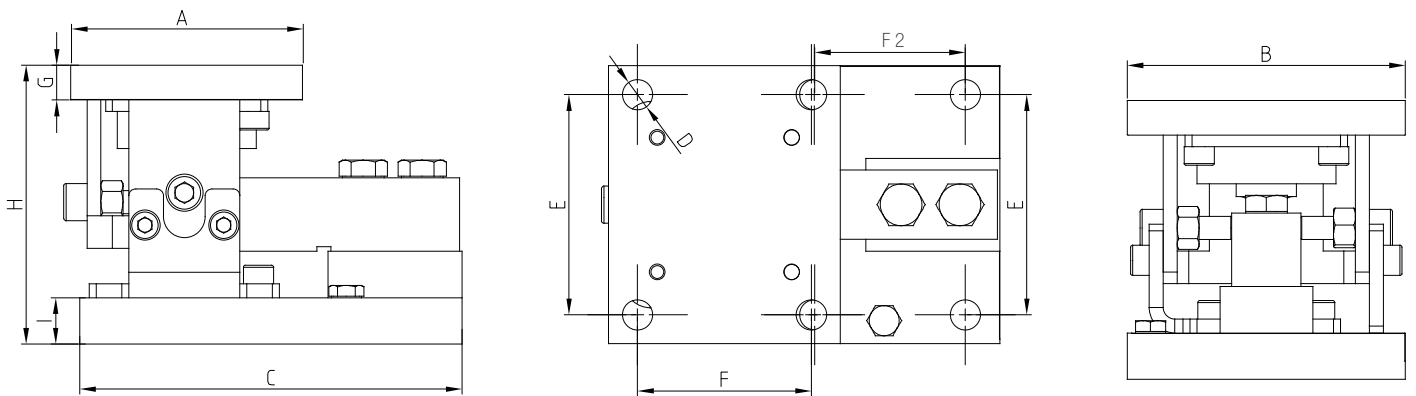

	A	B	C	D	E	F	F2	G	H	I
LEB FL 2	100	120	165	∅13	95	75	65	15	120±3	20
LEB FL 5 / 5L	140	150	220	∅17	120	110	90	20	152±1	20
LEB RC 2	100	120	165	∅13	95	75	65	15	110±3	20
LEB RC 5 / 5L	140	150	220	∅17	120	110	90	20	140±1	20
LEB SP 2	100	120	165	∅13	95	75	65	15	110±3	20
LEB SP 5 / 5L	140	150	220	∅17	120	110	90	20	140±1	20

Tank weighing system with 3 load cells

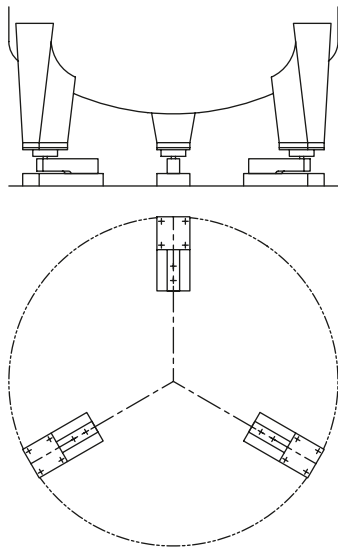

Platform scale with 4 load cells

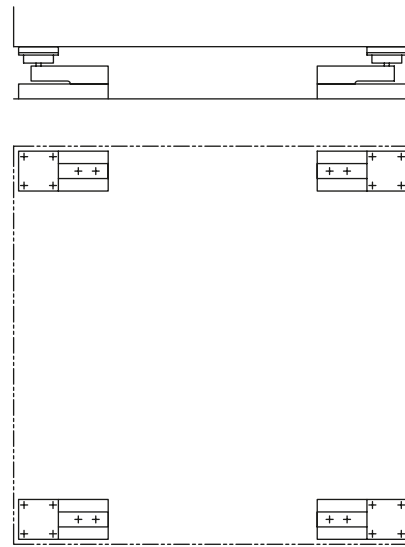

## Load cells compatible with LEB Weigh Modules

Capacities: 100kg ~ 5000kg	
Brand	Model
Baykon	BS063 / BS063S / BS063SD
Flintec	SLB, SB14, SB4, SB5
Vishay	3410, 3510, 3420