

LACH Weigh Module

For High Capacity Compression Load Cells



Applications



Tank & Silo



Industrial Processes

Key Features

- 47-68-100-150 tons capacity,
- High accuracy,
- Mounting without load cell,
- Easy and practical load cell change,
- Built-in anti-lift protection,
- Built-in side load protection,
- Painted, galvanized and 304/316 stainless steel models.

The LACH Weighing Module is especially designed for high capacity tank and silo scales. It is used with BR110/110S ring type load cells with capacities of 47 tons, 68 tons, 100 tons and 150 tons. The LACH weigh module can be mounted without a load cell, allowing for easy load cell replacement when needed. This feature prevents the load cell from being damaged during montage and welding processes.

The LACH weighing module has an integrated anti-rotation and lift-up protection against lateral movements and against lifting of the tank or silo by the wind effect when it is empty.

The LACH module is available in static painted, galvanized and 304/316 stainless steel versions.

Technical Specifications

Dimensions (mm)

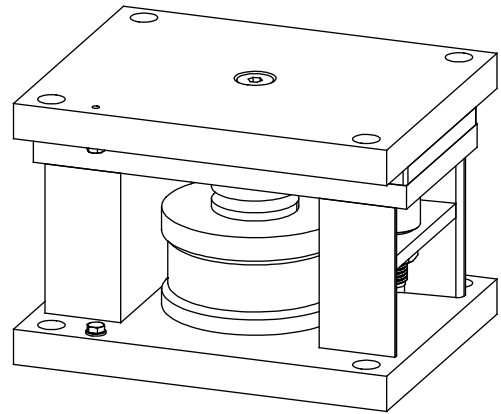
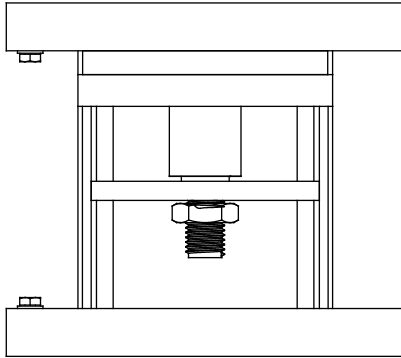
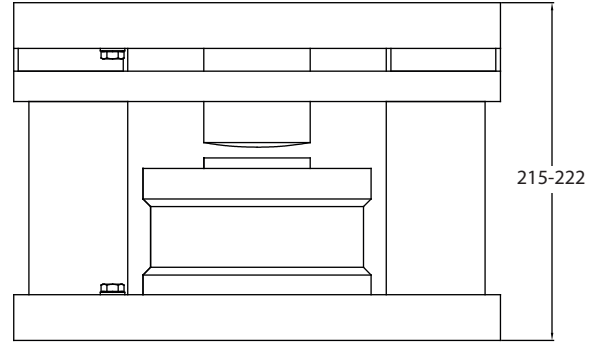
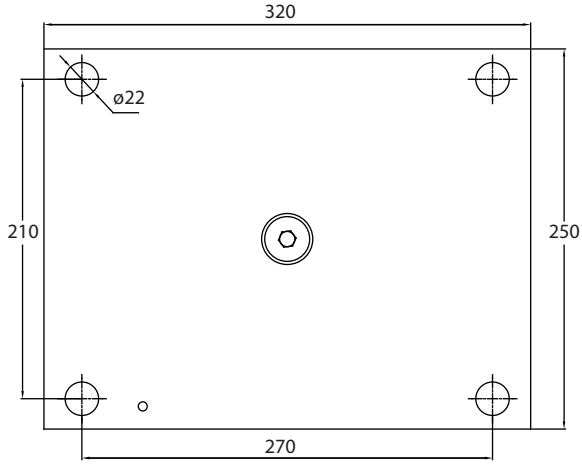

LACH Load cells compatible with the kit

Capacities: 47 - 68 - 100 - 150 ton

Brand	Model
Baykon	BR110 / BR110S