

LEB/FT - FTM Weigh Module

For Beam Type Load Cell

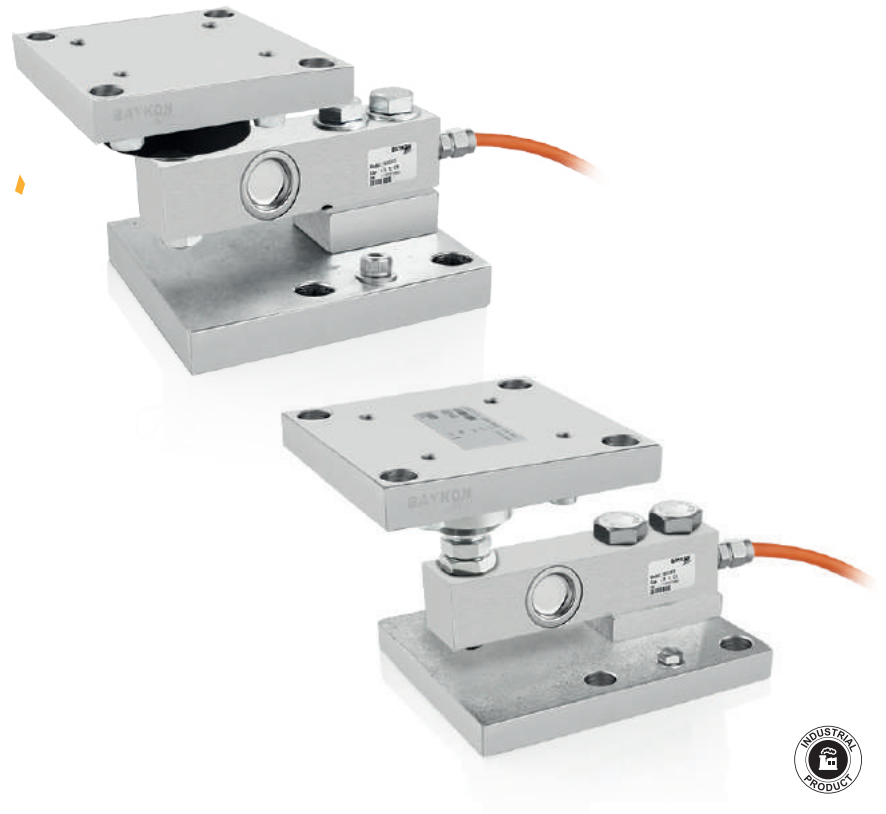

Applications



Tank & Silo



Floor Scales

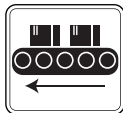

Conveyor Scales

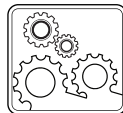

Industrial Processes

Key Features

- Low cost,
- Capacities from 100 kg up to 5000 kg,
- Integrated lift-up protection,
- Variants with ball foot and rubber with flange,
- Painted, galvanized and stainless steel models,
- PVC coated model for highly corrosive acidic environments.

Baykon LEB/FT ball foot and LEB/FTM flanged rubber foot weigh modules are low cost weigh modules designed for tank, silo, hopper and platform scales.

LEB/FT is suitable for use in non-mixer applications and LEB/FTM low-speed mixer constructions, and both models have a self-integrated anti-lifting structure.

Painted, galvanized and stainless steel models and PVC coated models are available for extremely corrosive acidic environments.

Technical Specifications

Dimensions (mm)

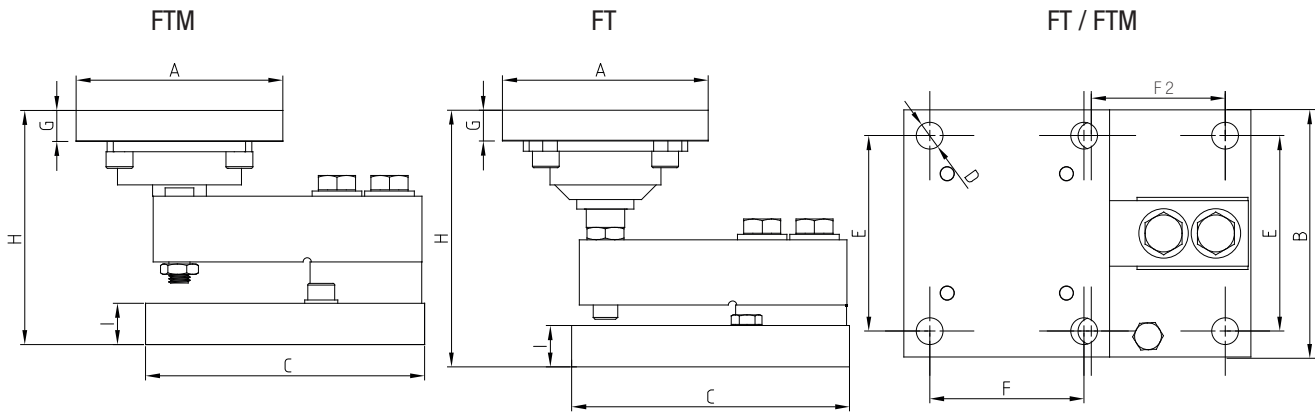

	A	B	C	D	E	F	F2	G	H	I
LEB FT 2	100	120	135	∅13	95	75	65	15	125 ⁺⁶ ₋₁	20
LEB FT 5	140	150	180	∅17	120	110	90	20	150 ⁺¹⁰ ₋₁	20
LEB FTM 2	100	120	135	∅13	95	75	65	15	115 ⁺¹	20
LEB FTM 5	140	150	180	∅17	120	110	90	20	140 ⁺¹	20

Tank weighing system with 3 load cells

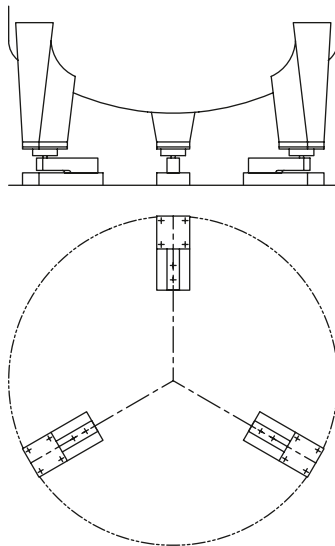

Platform scale with 4 load cells

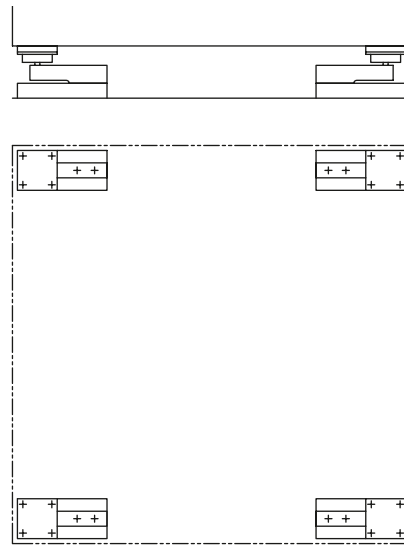

Load cells compatible with LAB Weigh Modules

Capacities: 100kg ~ 5000kg	
Brand	Model
Baykon	BS063 / BS063S / BS063SD
Flintec	SLB, SB14, SB4, SB5
Vishay	3410, 3510, 3420