

LAC Weigh Module

For Ring Type Load Cells

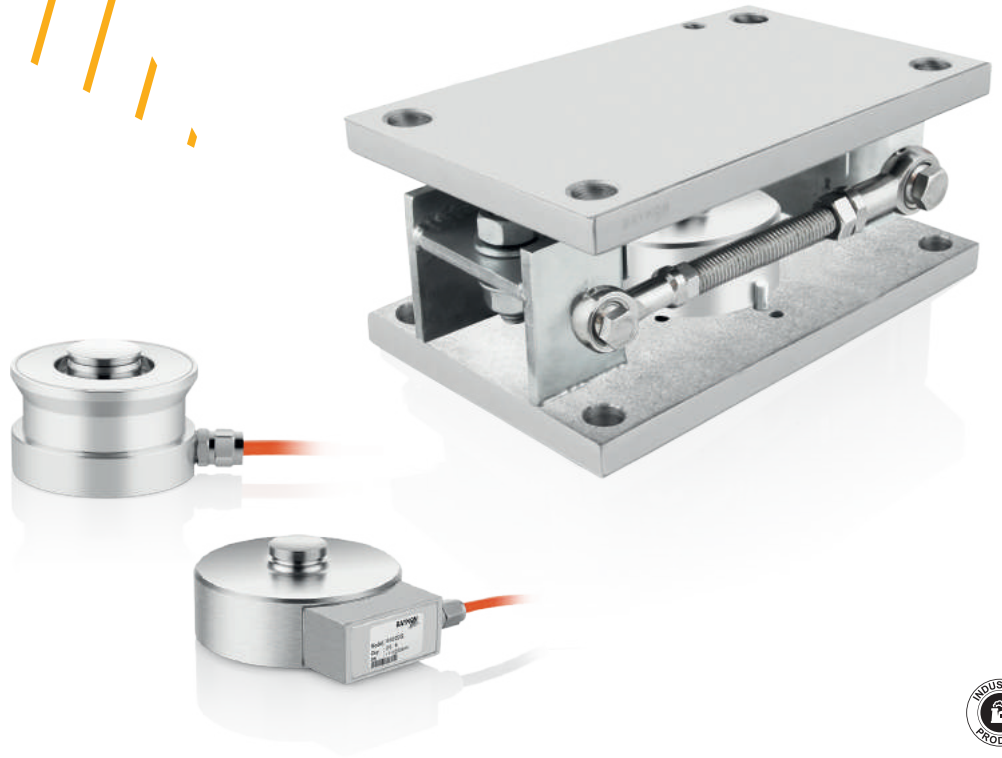

Applications



Tank & Silo

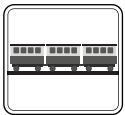

Railroad Truck Scales



High Capacity Applications



Industrial Processes

Key Features

- Capacities from 1t up to 47t.
- Allows installation without load cell.
- Easy and practical load cell replacement.
- Integrated lift up protection.
- Levelling plate provides protection against minor lateral forces.
- Optional FlexROD for extra safety if needed.
- Painted, galvanized steel models are standard.
- 304/316 quality stainless steel as option.

LAC weigh module is designed for tank, silo, reactor and conveyor scales. It is a low height design can be used ring type BR200S, BR110/110S load cells. Thanks to integrated anti-lifting mechanism allows safety installation without load cell to prevent load cell damage during installation and welding work. Levelling plate provides protection against minor lateral forces. However, FlexROD connection can be used when additional security is needed.

Anti-Lifting Bolts with Anti-Lifting Nuts and Fixing Nuts are used to lock module to install without load cell. After installation, locking nuts are taken to their proper positions. Levelling plate helps proper positioning of module. It also provides protection against minor lateral forces. LAC is available as painted, galvanized or 304/316 quality stainless steel types.

Installation without load cell

Anti-Lifting Bolts with Anti-Lifting Nuts and Locking Nuts are used to lock module to install without load cell. After installation, locking nuts are taken up and anti-lifting nuts is removed down about 2-3mm.

Levelling plate helps proper positioning of module. It is also affective against minor lateral forces. Additional FlexROD can be fastened against strong lateral forces for higher safety.

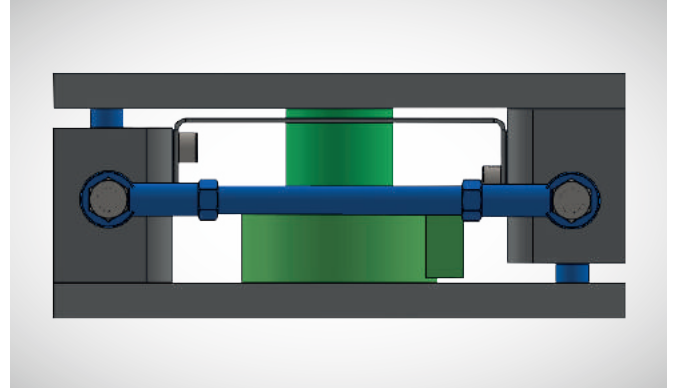
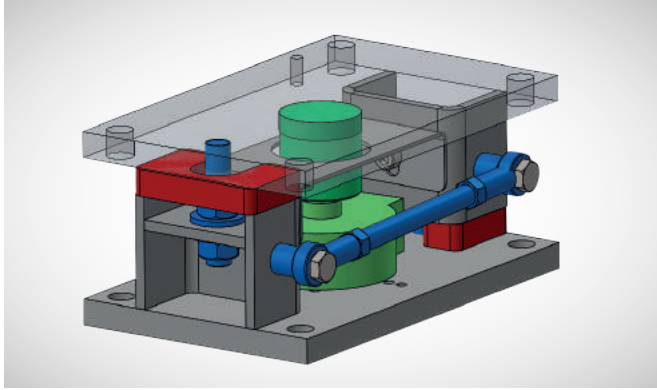
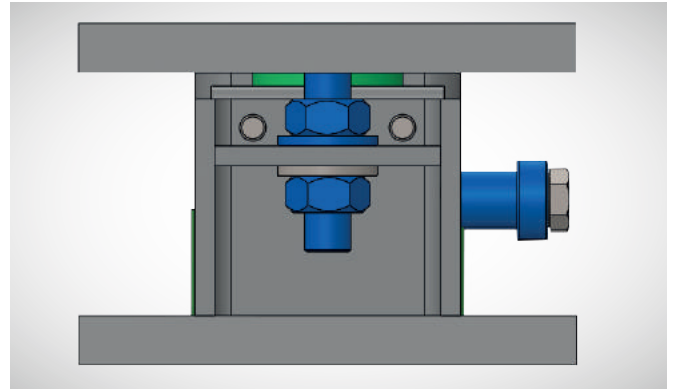

Dimensions (mm)

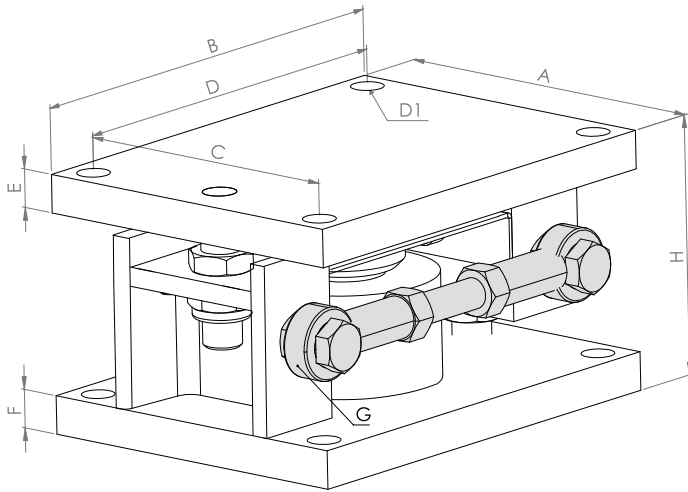

LAC110	1-4.7t	10-15-22t	33t	47t
LAC200	-	5-10-15-20t	-	-
A	150	150	180	220
B	240	240	300	380
C	120	120	150	180
D	210	210	270	340
E	15	15	20	20
F	15	15	20	20
G	M12	M12	M16	M16
H	103-110	103-110	135-145	155-170
D1	ø15	ø15	ø17	ø21

Load cells compatible with LAC Weigh Modules

Capacities: 1000 ~ 47000 kg

Brand	Model
Baykon	BR110 / BR110S / BR200S