

Forklift Scale
Turn Your Forklift into a Weighing Station



MagicFORKS® FK

BAYKON
Industrial Weighing Systems

With Baykon MagicFORKS® FK, you can transform your forklift truck into a weighing station by adding Weighing, Labelling and Data Management functions.

- ✓ Ideal for Warehouses, Freight Terminals and Recycling Centers.
- ✓ Speed up your handling operation; weigh your cargo on-site and in transit.
- ✓ Save time and money; the quickest way to check the weight of pallet.
- ✓ Data management; seamless integration records electronically to your Server.

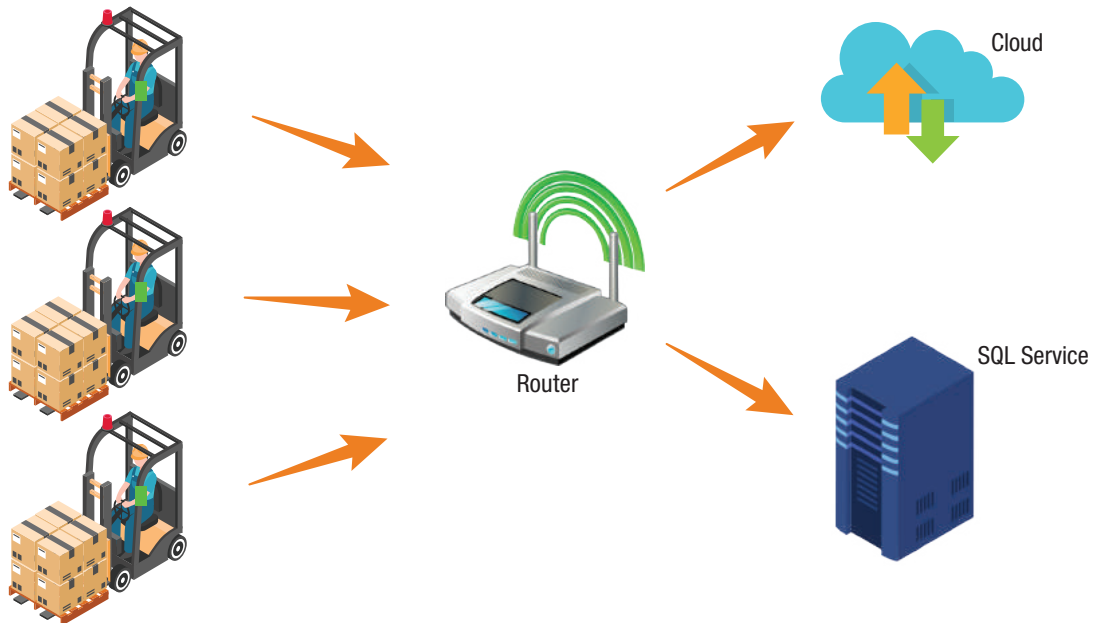

Data management with MagicFORKS® FK Terminal via Ethernet Wi-Fi option

Fully Wireless

The scale and the BX65 terminal are connected with Bluetooth (2.1 Class 1 + EDR). When the scale is not in use, the batteries in the forks are automatically turned off via Bluetooth to extend its operating life. The battery charge level can be continuously monitored on the BX65 display.



Supports Workspace Safety

IP Camera connection

The live views from the front and rear cameras can be monitored at the BX65 Terminal.



Tilt Sensor (optional)

If the tilt of the forks or the ground is greater than $\pm 5^\circ$, a colour warning appears on the BX65 display.





Scale

- ✓ Capacities: 2.5 t, 3 t and 5 t
- ✓ Consists of 2 pieces weighing forks and terminal.

Digital Loadcell Technology Provides

- ✓ Easy adjustment, electronic calibration
- ✓ Safe weighing with a warning message in case of load cell failure



BX21/BX24 Terminal

- ✓ For weighing with basic operations
- ✓ Configurable labels and 2 different info entries
- ✓ Totalizing function for serial batch weighing
- ✓ Standard interfaces for accesorie: 2 x RS232C, Bluetooth, USB, Ethernet TCP/IP, Wi-Fi



BX65 Smart Touch Terminal

- ✓ User configurable Weighing Menu, Label and Report
- ✓ Totalizing function for serial loading operations
- ✓ Up to 12 weighing related data entry
- ✓ Transactions stored in memory
- ✓ ERP integration alternatives including Web Service
- ✓ 7" Color touchscreen TFT monitor visible under direct sun
- ✓ Standard interfaces for accesorie: 2 x USB, RS232C, Bluetooth, Ethernet TCP/IP, Wi-Fi
- ✓ Supports workspace safety with Front and Rear Cameras



Easy Installation

Thanks to a completely wireless connection, MagicFORKS® FK can be easily mounted on your forklift truck in minutes, and if necessary, it can be quickly moved to another forklift truck.

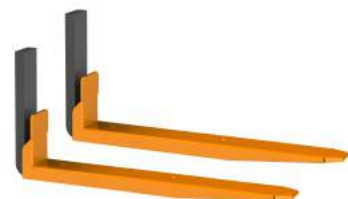

Technical Specifications

Specifications	
Capacity x increments	2500 kg x 1kg / 3000 kg x 1 kg / 5000 kg x 2 kg
Accuracy	0.1% of lifted load
Calibration	Zero & Span, Electronic calibration (eCAL) without test weight
Overload	%150 FS
Internal communication	Wireless with Class1, Bluetooth v4.2 + EDR End
Power supply	TA (10-28VDC), TB (20-72VDC), TC (40-160VDC)
Battery pack	7.4V / 7000mA Li-ion battery with a stainless steel housing (for each fork).
Auto sleep	The battery automatically turns off after a programmable time.
Operation period	65 hours of continuous operation, weeks without recharging under normal operating conditions
Battery charger	It can charge two batteries at the same time and supplied with 220 VAC adapter.

Accessories



Barcode Reader



RFID Reader



Printer



IP camera



Remote Display



Tower Lamp

Fork Sizes (mm)

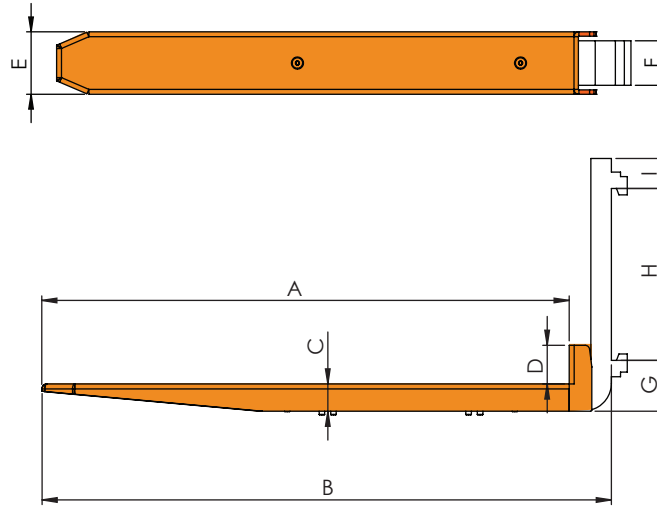

Model	Capacity	Class	A	B	C	D	E	F	G	H
MFK02A	2.5 t	ISO/FEM2A	1160	1250	60	175	140	100	76	418
MFK02B		ISO/FEM2B							152	
MFK03A	3 t	ISO/FEM3A	1160	1250	60	225	160	125	76	518
MFK03B		ISO/FEM3B							203	
MFK05A	5 t	ISO/FEM3A	1160	1265	75	225	175	140	76	518