

LARC3SW Weigh Module

For Compression Type Load Cells



Applications



Explosive
Atmospheres



Tank, Bunker,
Silo Weighing



Industrial
Processes

Key Features

- Capacities: 7.5t / 15t / 22.5t / 30t
- Easy to install and maintain
- Safe installation without load cells
- Optional single or dual check link integration
- Integrated lift-off protection
- Standard galvanized steel
- Optional stainless steel

BAYKON LARC3SW weigh module is designed for column type load cells up to 30t capacities. Their typical features are low profile design, balanced load transfer, built-in lateral movement control and integrated lift-off protection.

Lateral movement to all direction is blocked. Up to two optional stabilizers can be added to weigh module to stabilize weighing against swinging, rotational torque or for in-motion weighing. LARC3SW offers perfect solution especially for tanks, silos, high capacity conveyor scales.

BAYKON
Industrial Weighing Systems

Technical Specifications

Dimensions (mm)

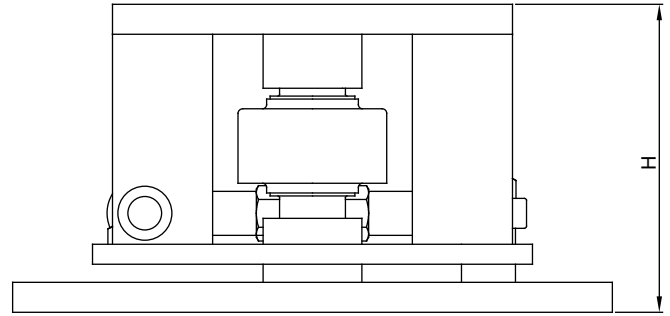
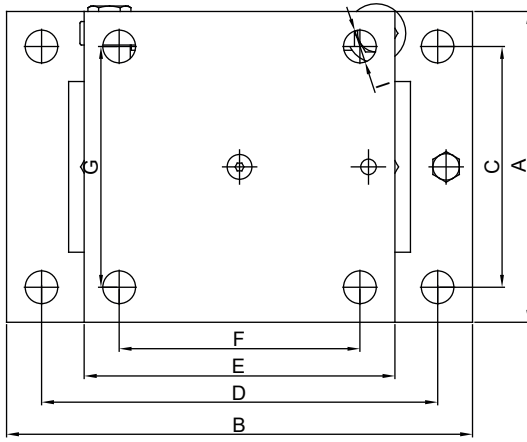

LARC3SW Mounting Kit

Cap. (t)	A	B	C	D	E	F	G	H	I
7.5 - 15 t	200	300	155	255	200	155	155	153	ø22
22.5 - t	200	300	155	255	200	155	155	164	ø22
30 t	200	300	155	255	200	155	155	210	ø22

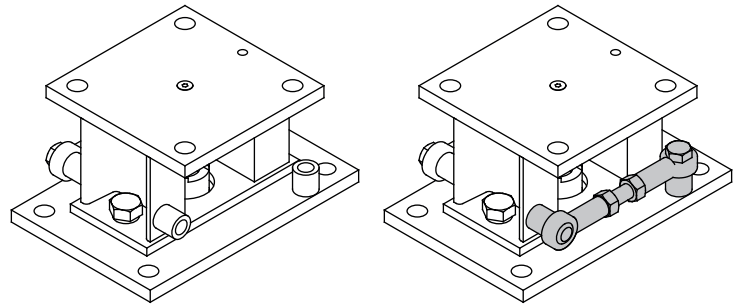

WS (With Stabilizer Option)

Application

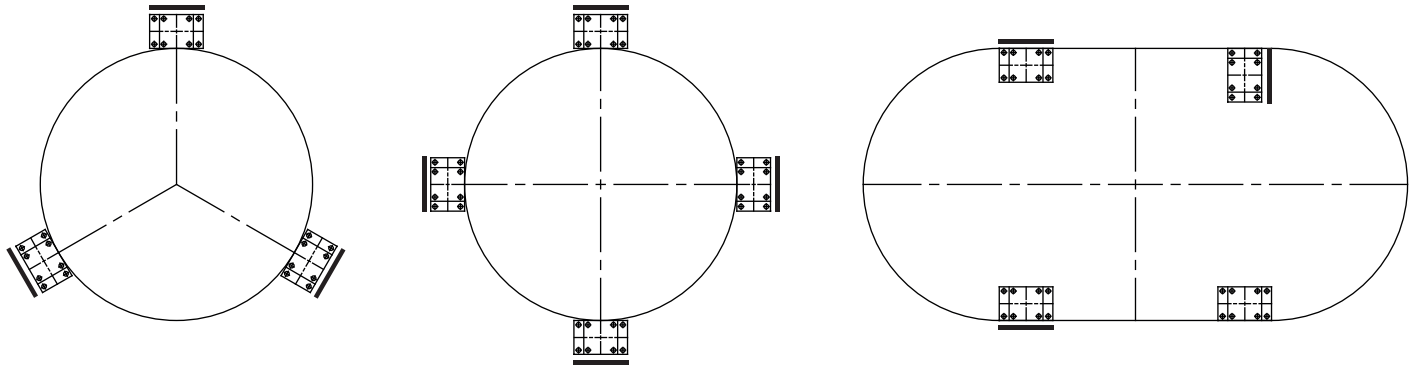

— : WS (With Stabilizer Option)

Load cells compatible with the kit

Model
Flintec RC3 7.5 t
Flintec RC3 15 t
Flintec RC3 22.5 t
Flintec RC3 30 t