

BU Pallet Scale

Mobile, fast and easy weighing

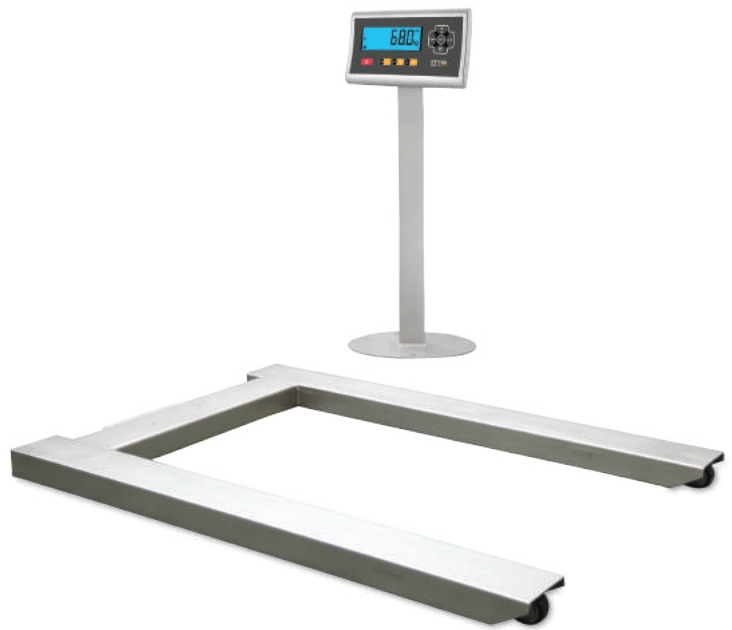

Ergonomic Design

- Easy portability with lightweight and integrated wheels
- Optional battery operation
- Depending on industrial environment, static painted, galvanised or stainless steel construction
- Optionally use in hazardous areas



Accurate and Reliable Weighing

- IP67 protected, OIML approved and high quality load cells
- Shock resistant robust construction
- Standard 1500kg & 3000kg capacities with 1260 x 1000 mm size



Functionality

- Functional use such as labelling, formulation, and filling control with mobile weighing electronics.
- Advanced or simple weighing applications; Labelling, formulation, piece counting, filling, formulation, classifying, checking or process integrations



BAYKON BU pallet scales provides easy loading and fast weighing with portable construction. It's practical and accurate weighing for loads with pallets. It is designed to supply accurate and reliable weighing for years in any kind of industrial environments.

BAYKON BU pallet scales are compatible with OIML standards and it is produced according to European directives up to 2 x 3000d multi range accuracy classes.

BAYKON BU pallet scales are used in food, cosmetic, metal and metallurgy, logistic, chemical and in all industries at goods receiving and shipping, manufacturing, packaging application areas.

Technical Specifications

Models	Weighing Capacities		
	1500 kg	3000 kg	
BU 1500	●		
BU 3000		●	
Readability			
OML Approved	Single range	500 g	1 kg
	2 x 3000e Multi range	200 / 500 g	500 g / 1 kg
Non-approved industrial usage		100 g	200 g
Measurement limits			
Minimum weighing range	10 kg	20 kg	
Repeatability	0,15 kg	0,30 kg	
Zeroing range	+ / - 30 kg	+ / - 60 kg	
Taring range	From 0 kg to maximum capacity		
Overload limit (Static)	1800 kg	3200 kg	
Construction			
Fork height	85 mm		
Number of load cells	4		
Material	Standard static painted, optionally galvanised or stainless steel		
Protection class	IP65 / IP67 (optional) / IP68 (optional)		
Holding handle and wheels	Standard		
Indicator			
Specifications	All BAYKON indicators or terminals can be connected. Please refer to the brochure of the weighing instrument for detailed information.		

Sizes(mm)

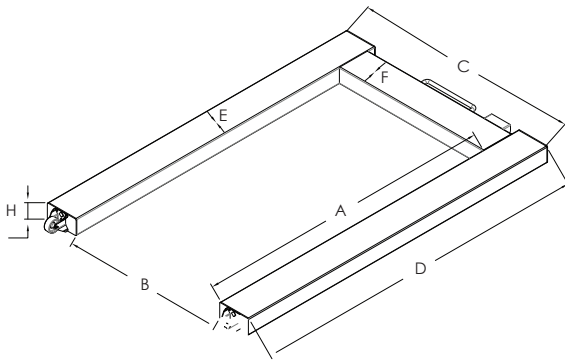

	A	B	C	D	E	F	H
BU	1062	600	840	1255±5	120	140	85
BU IBC	955	600	1040	1200±5	220	220	80

Options



Washable stainless steel construction

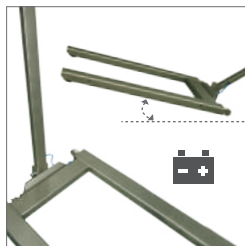

Transport wheels, indicator column and battery



Peripheral and wireless communication



Data collection software



Ex-Proof