

# BX07M Terminal

For Industrial Mobile Weighing Applications



## Wireless Connection with Load Cell

- Connection to analogue or digital load cells and scales without cable.
- Battery status indication and automatic sleep mode for battery - powered load cells.



BX07M is a Windows CE based industrial terminal with IP65 protected stainless steel housing and designed for mobile weighing applications. Its wireless communication with analogue or digital load cell-based weighing platform / scales provides enormous flexibility for industrial mobile weighing applications.



## Flexible Weighing Operation with

- User configurable Weighing Menu, Label and Report
- Serial and additive totalizing mode with total ticket
- Peripherals; Barcode/RFID Readers, Printer, Remote Display, USB Flash

BX07M terminal's standard labelling and data collection software offers a customized weighing menu and ticket design with barcode. Transactional weighing data can be entered easily with 7" color touch screen monitor, wireless barcode and external PC keyboard. Peripherals like printers, barcode readers, remote display can be connected directly.



## Powerful Data Integration

- Web Service for online transfer to SQL Server
- File transfer as Excel to a PC by Data Editor software
- Data export to USB memory as Excel file

Weighing records saved in the terminal can be transferred directly to SQL Server with Web Service. Excel file transfer is also possible into USB memory or to a PC with Data Editor software.

Battery status is shown on BX07M monitor at battery powered scales. BX07M puts the battery powered load cell interface unit into sleep mode automatically to increase the battery operation time if the scale is at a standstill for a pre-programmed time.

# Technical Specifications

Software	Standard Labelling as Single, Serial and additive Totalizing, User configurable Weighing Menu, Customized Software ( Call Baykon )		
Operating system	WinCE 6.0		
Display	7" color TFT touch screen monitor		
Calibration	Zero & Span, or electronic calibration without test weight		
Auto sleep	Automatic sleep mode with programmable standstill time for the Li-ion battery powered MTx02		
Overload	RED color display indication		
Communication with Load cell interface unit	Baykon Master Bluetooth		
Standard interfaces	RS232C, 2xUSB, Ethernet TCP/IP		
Optional interfaces	Wi-Fi ( Cannot be used together with Ethernet TCP/IP ) Bluetooth ( Cannot be used together with RS232C )		
Power supply	10-30VDC - Optional 48VDC		
Accessories	Text & Label Printer, Barcode/RFI reader (Wireless or cable) Remote Display, USB Memory, PC Keyboard		
Data transfer	Direct transfer into USB Memory as Excel file, Excel File transfer to a PC via Data Editor Software Online transfer to SQL Server via Web Service		
Housing	Stainless steel, IP65 protected		
<b>Models of load cell interface unit</b>			
Digital load cell interface units	MTD01		MTD02
Analogue load cell interface units	MTA01		MTA02
Communication with BX07M	Baykon Slave Bluetooth		

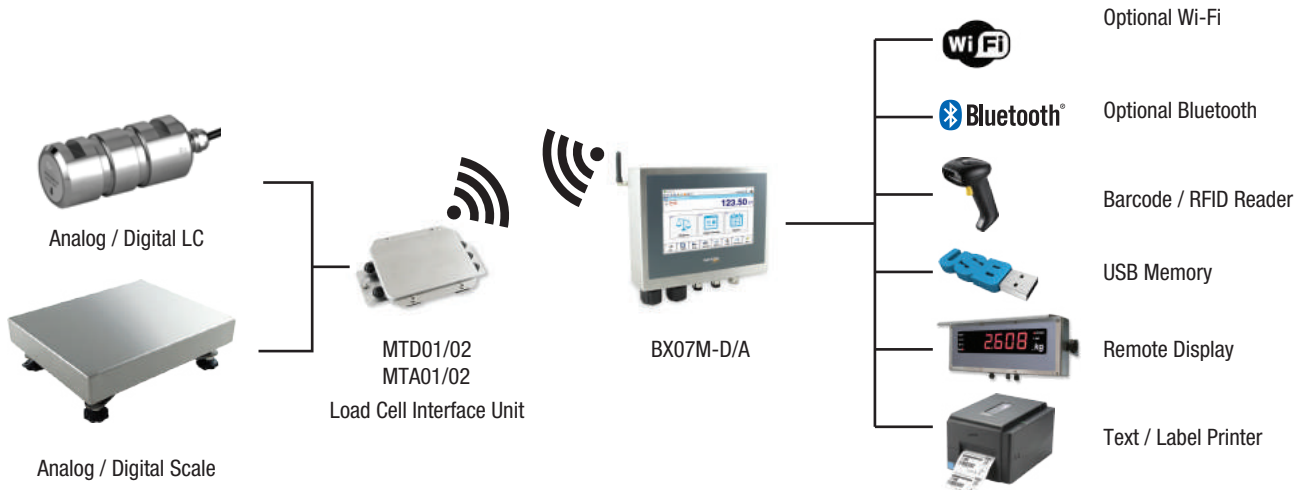

# Dimensions (mm)

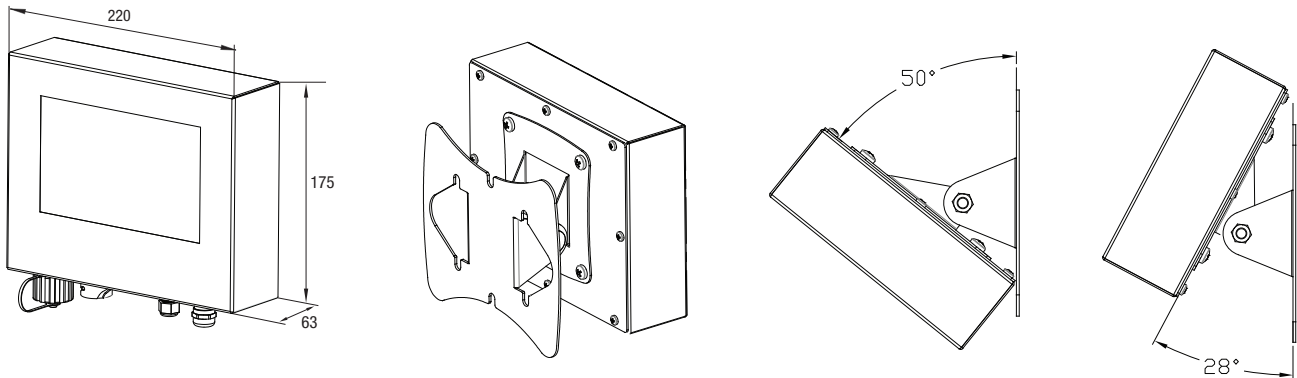

(Specifications are subject to change without notice. 01 - 01 / 2021)